

BH Bulk Hopper



Glimek Bulk Hopper BH with automatic measuring/portioning device enables a smooth and accurate feeding of a divider or similar applications. The electrical and pneumatic controls are normally built in into the electrical cabinet of the Bowl Lift.



Sveba Dahlen Group

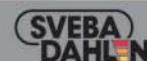

Scandinavian know-how – worldwide

BH Bulk Hopper

Volume is 132 US gal = approximately 661 lb dough



Two photocells mounted on the hopper. One for dough cutting and time relays and the other for controlling the dough level in the feeded equipment.



Can be mounted on movable racks feeding two different lines

Bulk hopper in stainless steel

The pneumatic dough knife system enables a precise weight accuracy

Accessories

Customized Bulk Hopper	Special customized designed Bulk Hopper adapted to the equipment to feed
Dough Conveyor	Horizontally mounted under the bulk hopper with scraper on the belt. Width 19 2/3", standard length 78 3/4"
Dough Conveyor - additional length	Additional length above 78 3/4"
Dough Conveyor - reversibel drive of conveyer	Change the direction of the conveyer. Photocell for dough level included
Hopper Lubrication	Automatic lubrication inside bulk hopper by a spread tube system on top of the hopper. Separate unit with control box, pump unit and a built in oil container
Non-stick coating of the hopper	Interior of the dough hopper non-stick to assure a smooth infeed of the dough
Safety Guard	Customized safety guard for infeed of custom equipment
Service Platform, attached to frame	Service platform with staircase and guard rails attached to frame of bulk hopper
Service Platform, customized	Service platform designed according to customer
Stainless steel frame	Stainless steel frame instead of painted (standard)

Technical data

Material bulk hopper	Stainless steel
Material lower frame	Painted
Volume, standard	20 1/3 ft ³
Dough capacity	Approx. 770 lb
Air supply	Compressed air, min 87 PSI, approx. 0,2 CFM
Requires compressed air min. 6 bar	

All order confirmations of bulk hopper include a technical drawing

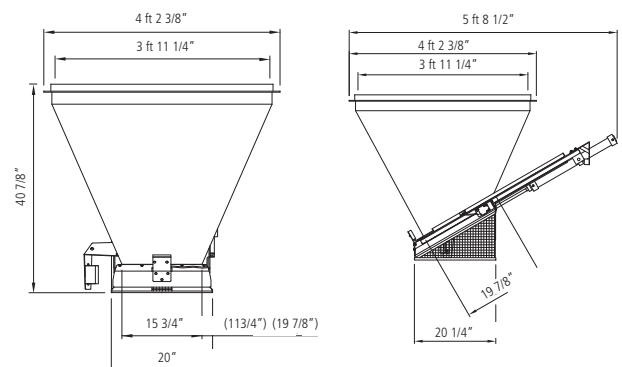

Glimek AB
Box 124
S-280 64 GLIMÅKRA
Sweden
Tel. int. +46-(0)44 449 00 • Fax +46-(0)44 449 10
e-mail: office@glimek.se • www.glimek.se



Belshaw Adamatic Bakery Group
814 44th St NW
Suite 103
Auburn Washington 98001
USA
Phone: +1 732 544 8400
Fax: +1 732 544 0735