

BL Bowl Lift



Glimek BL is a solid bowl lift for lifting and tipping a bowl into a bulk hopper, directly into a divider or other similar applications. The lifting capacity is up to 1322 lbs (including bowl). Standard version is adapted to Glimek Mixers. Can be modified for other mixing bowls from other manufacturers as well.



Sveba Dahlen Group



Scandinavian know-how – worldwide

BL Bowl Lift

Lift speed 16 ft/min

Lift capacity 1322 lb
(bowl including dough)



Safety guard with safety switch has to be in closed (secured) position in order to lift the bowl



Two gear motors lifts the bowl by two separate chains, each provided with a chain tension sensor



The lift is controlled with push buttons for up and down movement

Accessories

Bowl lift designed for bowls from other manufactures	The lift can be modified to fit bowls from other manufactures, however this has to be approved by Glimek technical department by order
Higher tipping height	For tipping height over 9 ft 5/6" and up to maximum 13 ft 1/8"
Straight forward tipping	Tipping in the same direction as the infeed of the bowl Side of column has to be stated when ordering

Technical data

Max total height	13 ft 11 3/8"
Max tipping height	9 ft 10 1/8" with Glimek SM-241 bowl
Lifting capacity	1322 lb
Lifting speed	16 ft/min
Power supply	1,1 kW

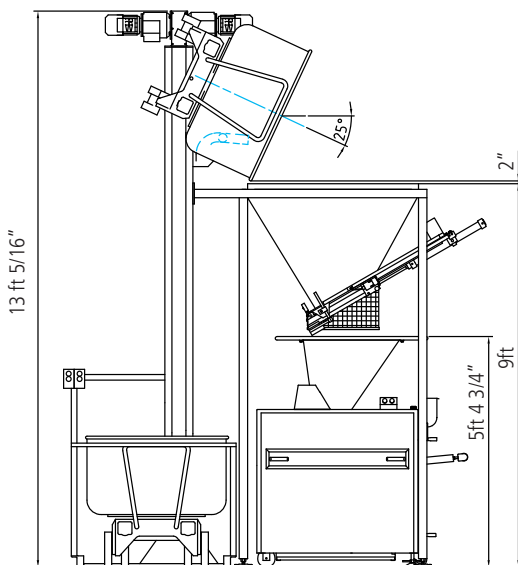

Lift can be made for left hand, right hand or straight a head tipping, please specify by order
All orderconfirmations of bowl lift includes a technical drawing



AE66



Glimek AB
Box 124
S-280 64 GLIMÄKRA
Sweden
Tel. int. +46-(0)44 449 00 • Fax +46-(0)44 449 10
e-mail: office@glimek.se • www.glimek.se



Belshaw Adamatic Bakery Group
814 44th St NW
Suite 103
Auburn Washington 98001
USA
Phone: +1 732 544 8400
Fax: +1 732 544 0735