

Artisan bread line

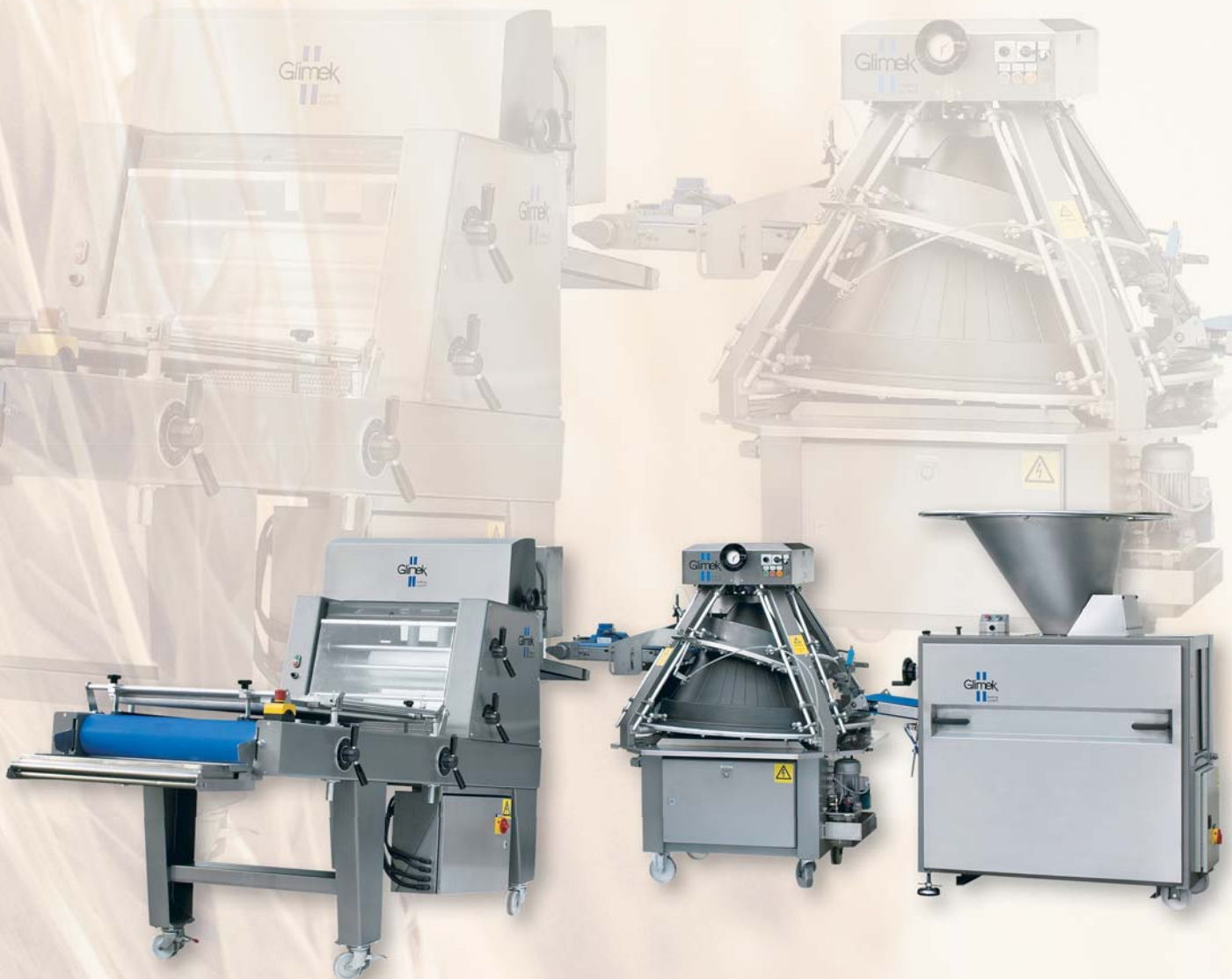

A bread line designed for processing very soft dough with a water content of 85%. Designed for production of Mediterranean bread as Ciabatta and other similar types of artisan bread. The line has a capacity up to 1800 pcs/hour. All machines are produced in Sweden according to the CE-regulations.

SDG



Sveba Dahlen Group

SVEBA
DAHLEN



Glimmek
baking system

Scandinavian know-how – worldwide

Artisan bread line

SD-180 Suction dough divider



- Hopper 26.4 US gal
- Non-stick coated hopper
- Oiling of belt
- Frequency converter
- Special non-stick outfeed belt
- Transfer roller
- Easy and safe handling and maintenance

Options:

- Minipiston 1.2 oz - 9 oz
- 59.5 US gal hopper

	SD180XS	SD 180	SD180XL
Weight range	2.5 oz - 2.2 lb	4.2 oz - 3.5 lb	6.34 oz - 5.0 lb
Capacity	750-1800 pcs/hour		

CR-310GM Conical rounder



- Centrally adjustable tracks
- Non-stick coated cone and tracks
- Rounding length up to 13 ft.
- Variable cone speed
- Automatic oiling unit
- Outfeed conveyor with transfer roller

Weight range	1.05 oz - 4 lb
Capacity	Up to 3600 pcs/hour

MO-930 Moulder



- Infeed conveyor with flour duster
- Motorized guiding rollers to ensure central infeed
- Variable speed
- Special non-stick belt
- Gentle dough treatment

Options:

- Flour duster before pressure board

Weight range	1.05 oz - 4 lb
Capacity	Up to 1800 pcs/hour

For further information:
www.glimek.se

1. SD-180
2. CR-310GM
3. MO-930

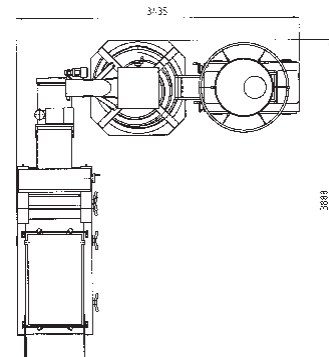
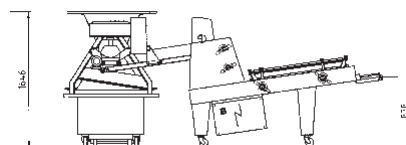
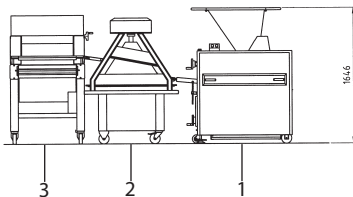

Glimek AB

P.O. Box 124 • S-280 64 GLIMÅKRA • Sweden
Phone +46 44 449 00 • Fax +46 44 449 10
e-mail: office@glimek.se • www.glimek.se



Belshaw Adamatic Bakery Group
814 44th St NW
Suite 103
Auburn Washington 98001
USA
Phone: +1 732 544 8400
Fax: +1 732 544 0735