

Straight dough line ECO



Glimek Straight dough line ECO is an economical version especially made for producing bread without need for an intermediate proving time. A very compact bread line with a capacity of up to 1800 pcs/h. The Straight dough line ECO is a special selection of Glimek's efficient machines. All machines are produced in Sweden according to the CE-regulations.

SDG



Sveba Dahlen Group

SVEBA
DAHLN



Glimek
baking system

Scandinavian know-how – worldwide

Straight dough line ECO

SD-180XS Suction dough divider



- Hopper 100 l
- CE-approved hopper guard
- Stainless steel covers
- Variable speed
- Very accurate scaling
- Stainless steel dough knife
- 5 m connection cable and CEE-plug
- Frequency converter drive
- Easy and safe handling and maintenance

Options:

- Flour duster, mechanical (stainless steel)

Weight range	70-1000 gr
Capacity	750-1800 pcs/hour

HU Hander up



- Economic rounding unit
- Rounding length 700 mm
- Placed on the extended outfeed belt of the SD-180
- Simple adjustments

Weight range	70-1200 gr
Capacity	Up to 1200 pcs/hour

CE100 Cup elevator



- Photocell controlled, working step by step to link up cone rounder with moulder type MO-671
- Electrical cabinet mounted on elevator

Weight range	70-1500 gr
Capacity	Up to 1800 pcs/hour

MO-671 Moulder "Midi"



- Very flexible moulder
- Working width up to 650 mm
- Two pair of rollers
- Foldable pressure board with two wedges in food approved plastic

Options:

- Variable speed
- Lower side guides, non-stick coated

Weight range	30-1800 gr
Capacity	Up to 3000 pcs/hour

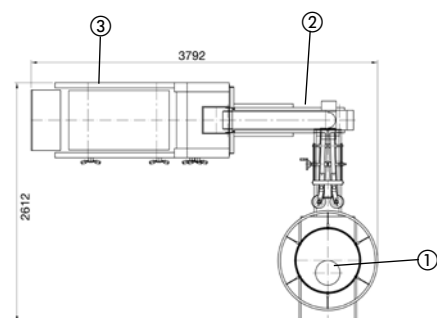
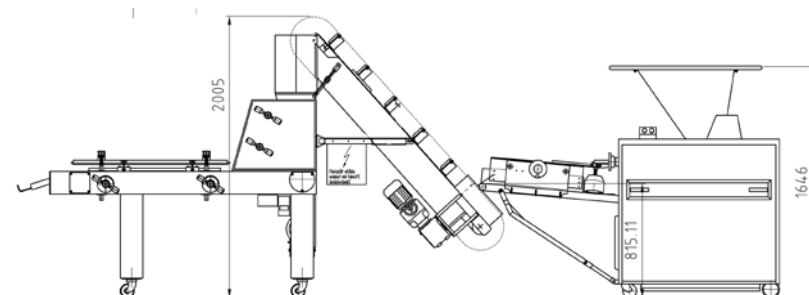

1. Dough divider SD-180XS with Hander up HU
2. Cup elevator CE-100
3. Moulder MO-671